



AMCA International

Understanding & Reducing Air System Noise

John D. Sofra

Market Manager - *Airflow Attenuation, Industrial, Environmental Markets*

Kinetics Noise Control, Inc., Dublin, Ohio

jsofra@kineticsnoise.com

Air System Engineering & Technology (ASET) Conference-US

San Antonio, TX • Hyatt Regency San Antonio Riverwalk • March 6 - 7, 2018

Copyright
AMCA International • www.amca.org

Professional Development Hours (PDH) Certificates

The Air Movement and Control Association International (AMCA), has met the standards and requirements of the Registered Continuing Education Providers Program. Credit earned on completion of this program will be reported to the RCEP. A certificate of completion will be issued to each participant. As such, it does not include content that may be deemed or construed to be an approval or endorsement by NCEES or RCEP.



Copyright Materials

This educational activity is protected by U.S. and International copyright laws. Reproduction, distribution, display, and use of the educational activity without written permission of the presenter is prohibited.

© AMCA International

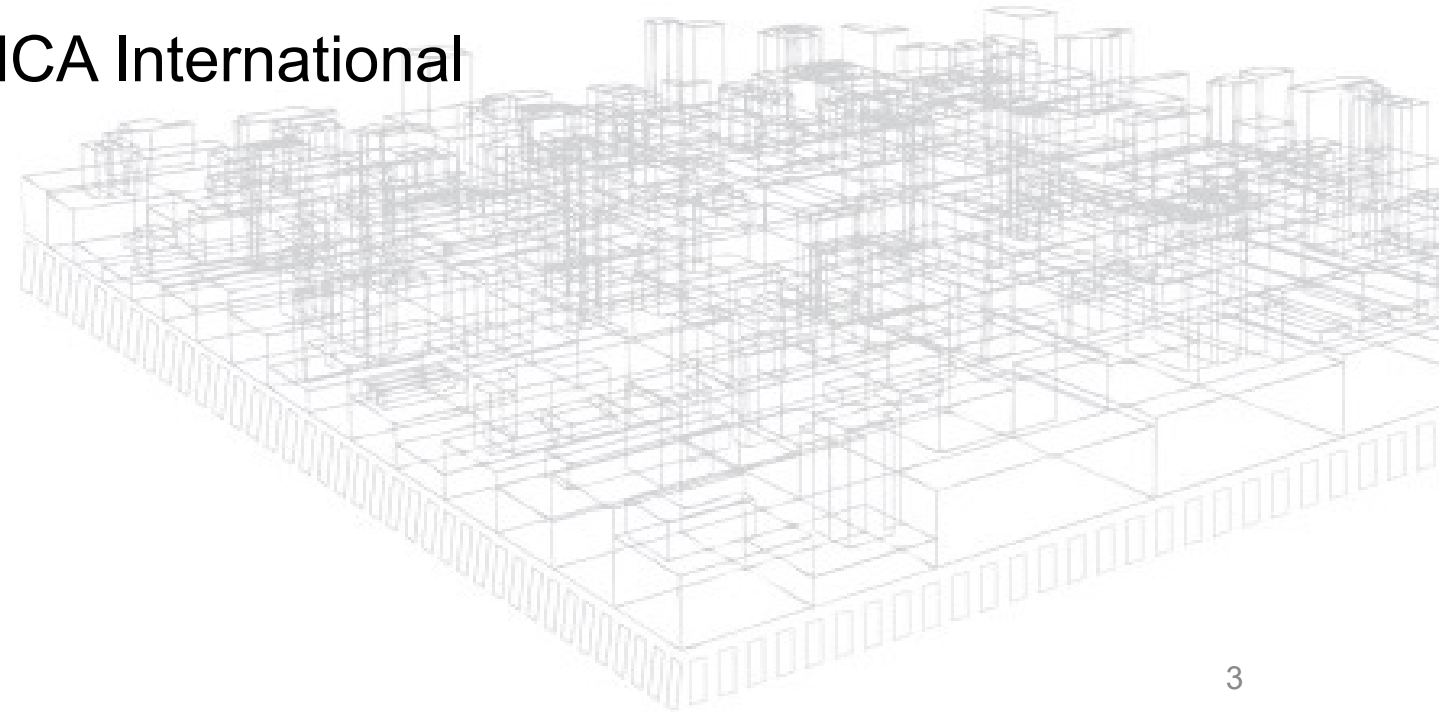

Learning Objectives

4

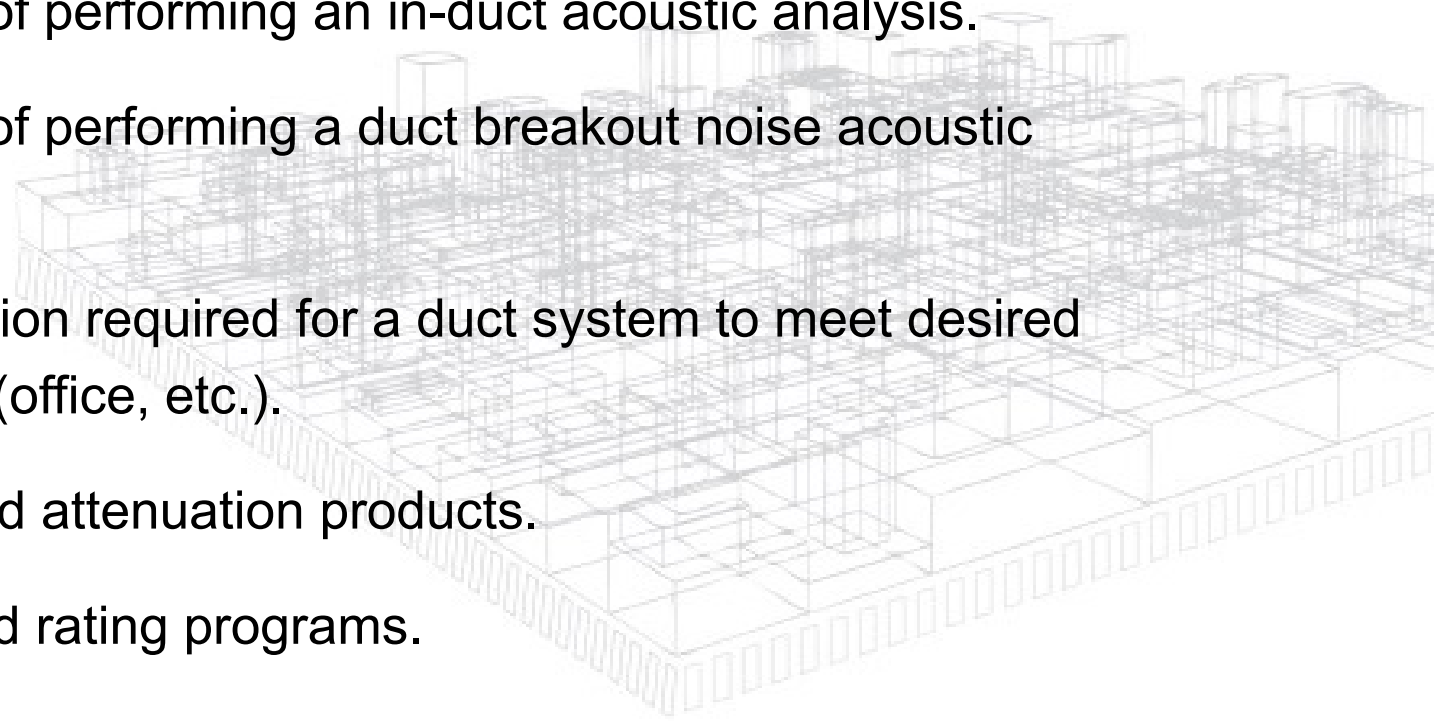
- Learn the basic concepts of how sound power, sound pressure and frequency interact.
 - Investigate the components of a duct system and how they generate and naturally attenuate (silence) sound.
 - Learn the proper methodology of performing an in-duct acoustic analysis.
 - Learn the proper methodology of performing a duct breakout noise acoustic analysis.
 - Learn to determine the attenuation required for a duct system to meet desired sound levels in a critical space (office, etc.).
 - Learn to select and locate sound attenuation products.
 - Review performance testing and rating programs.
- 

References

- ASHRAE Fundamentals Handbook – 2017, Chapter 8
- ASHRAE HVAC Applications Handbook – 2015, Chapter 48
- Noise Control for Buildings and Manufacturing Plants – Hoover & Keith, 2001
- SMACNA - HVAC Systems Duct Design Manual - 2006, 4th Edition

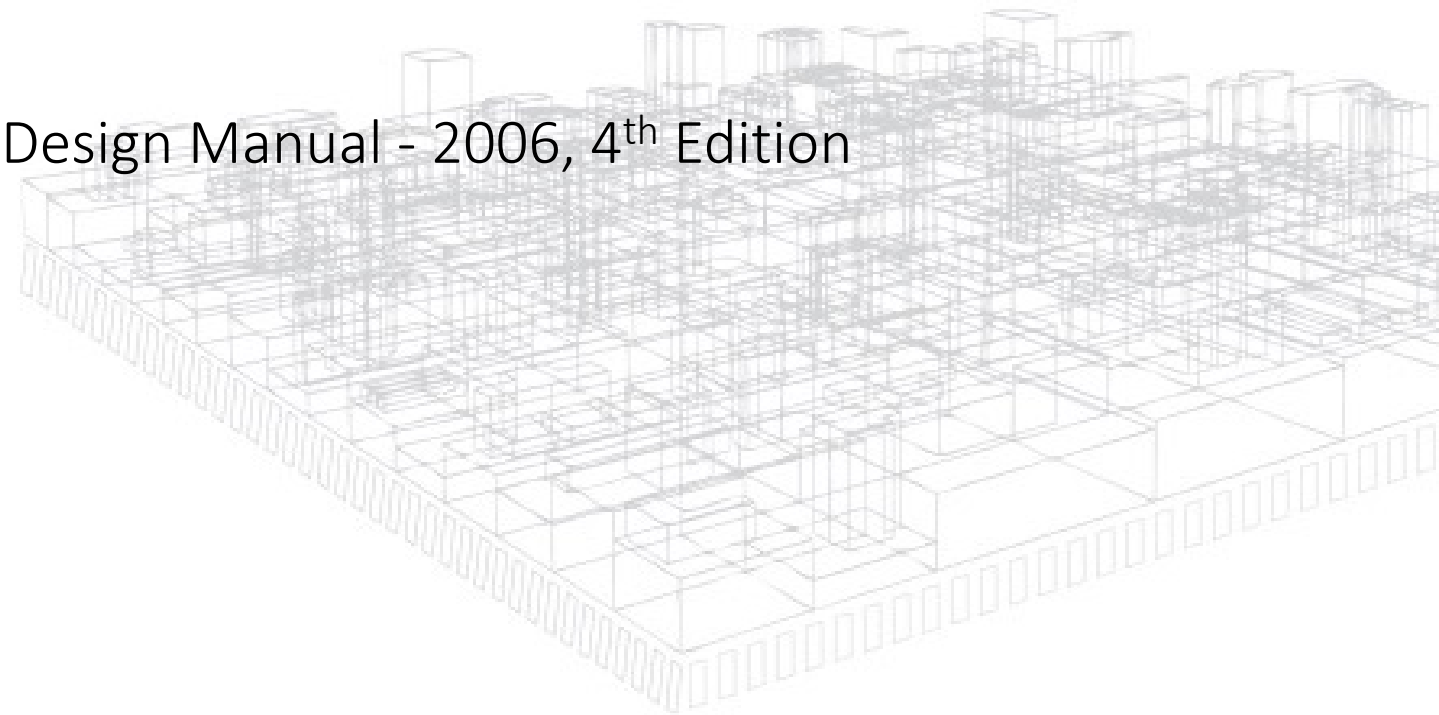

Noise and Sound

- Noise is unwanted sound.
- Sound is a propagating disturbance (a wave) in a fluid or solid.
- In a solid, this disturbance travels as bending, compressional, torsional or shear wave.
 - Structure-borne sound
- In a fluid, this disturbance travels as a longitudinal compression wave.
 - Airborne sound
- Airborne sound is typically addressed in the mechanical project scope.

Airborne Sound

- Airborne sound is generated by a vibrating surface or by a turbulent fluid (air) stream.
- Sound waves in air are variations in pressure above and below atmospheric pressure.
- Sound is created at a source (FAN), transmitted along one or more paths (DUCT), and reaches a receiver (CLASSROOM).

Sound Propagation

- Analyze both supply and return systems.
- Noise propagates regardless of airflow direction.

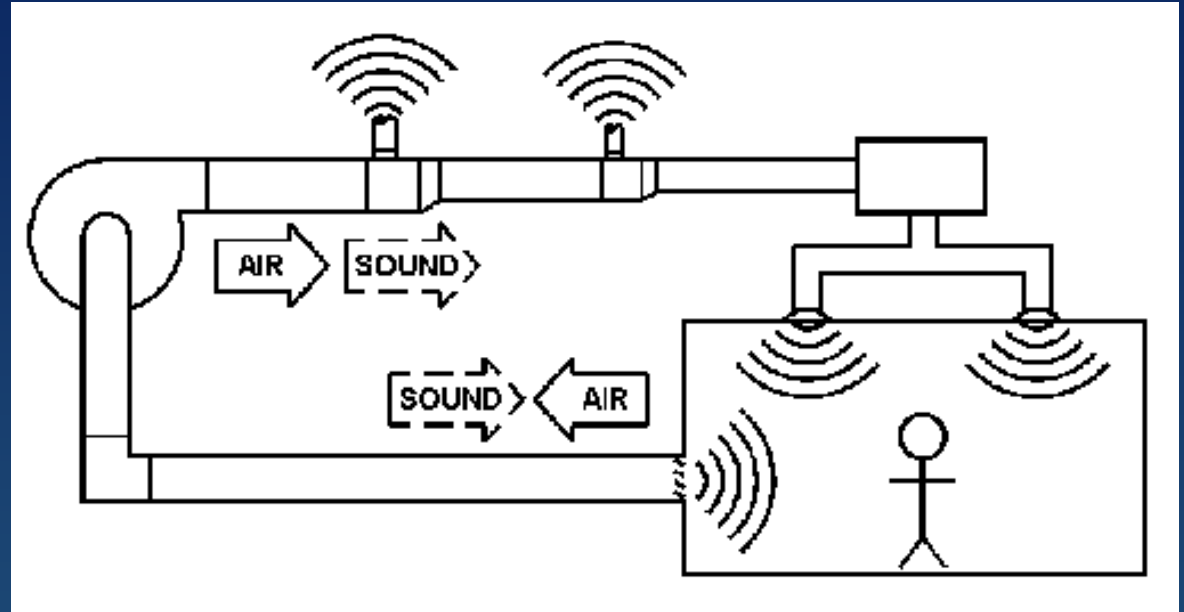

The Receiver and the Use of the Log Scale

- The threshold of hearing to the threshold of pain covers a range of approximately $10^{14}: 1$.
- The use of a logarithmic scale is used when describing the physical properties of sound.

$$\text{Level} = 10 * \log_{10} (A/A_{ref})$$

where,

A = magnitude of the physical property

A_{ref} = agreed upon reference value

A/A_{ref} is a unitless ratio; the logarithm of the ratio is given a unit of bels (B)

- A factor of 10 is multiplied to the logarithm to convert bels to decibels (dB)

Sound Power & Sound Power Levels (PWL)

- Sound Power, w , of a source is its rate of emission of acoustical energy, expressed in watts (W).
- Independent of location of receiver, or environmental surroundings.
- Sound Power Level, L_w (dB):

$$L_w = 10 \log (w/w_{ref})$$

where,

w = sound power emitted by the source, expressed in watts (W)

w_{ref} = reference sound power, 10^{-12} W

Sound Pressure & Sound Pressure Level (L_p)

- Sound pressure is the acoustic pressure caused by a sound wave.
- Sound power level is proportional to the square of sound pressure level, L_p (dB):

$$L_w \propto L_p^2$$

$$L_p = 10 \log (p/p_{ref})^2$$

$$L_p = 20 \log (p/p_{ref})$$

where,

p = sound pressure at the receiver, expressed in pascals (Pa)

P_{ref} = reference sound pressure in air, 20 μ Pa

How Do They Compare?

	Sound Power (watts)	Sound Pressure (pascals)	Lw (dB)	Lp (dB)
Threshold	0.00000000000001	0.00002	0	0
Normal Speech	0.000003	0.02	65	60
Passing Truck	0.03	2	105	100
Saturn Rocket	100,000,000	100,000	200	195

Which units would you rather work with?

Subjective Reaction to Changes in L_p

Subjective Change	Objective Change in Sound Power Level (Broadband Sound)
Much louder	More than 10 dB
“Twice” as Loud	+10 dB
Louder	+5 dB
Just Perceptibly Louder	+3 dB
Just Perceptibly Quieter	-3 dB
Quieter	-5 dB
“Half” as Loud	-10 dB
Much Quieter	Less than -10 dB

Characteristics of the Sound Wave

Frequency, (f)

- How often the changes in air pressure happen per unit of time
- Heard as pitch
- Most sounds we hear are a combination of many frequencies
- Measured in hertz (Hz), cycles per second

Wavelength, (λ)

- Distance between successive peaks in the wave:

$$\lambda = c/f$$

- Low frequency waves are more difficult to control with typical building materials.

Octave Band Wavelengths	
Frequency (Hz)	Wavelength (ft.)
63	17.9
125	9.0
250	4.5
500	2.3
1000	1.1
2000	0.6
4000	0.3
8000	0.1

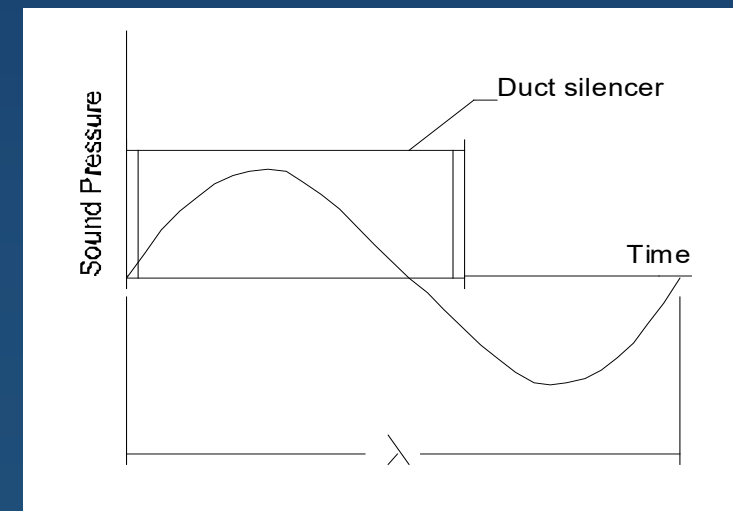

The Sound Spectrum

- To fully describe sound both frequency and magnitude (level) are required.
- Measurements for most HVAC noise control work are made at 8 octave bands (1/1 octave bands)

63 Hz, 125 Hz, 250 Hz, 500 Hz, 1000 Hz, 2000 Hz, 4000 Hz, 8000 Hz

- When discussing sound – 8 octave band values are required.

Log Scale Addition

Logarithmic addition of levels is non-linear:

Difference between levels to be combined, dB	0 to 1	2 to 4	5 to 9	10 & more
Number of dB to add to highest level	3	2	1	0

100 dB + 100 dB = 103 dB	100 dB + 94 dB = 101 dB
100 dB + 99 dB = 103 dB	100 dB + 93 dB = 101 dB
100 dB + 98 dB = 102 dB	100 dB + 92 dB = 101 dB
100 dB + 97 dB = 102 dB	100 dB + 91 dB = 101 dB
100 dB + 96 dB = 102 dB	100 dB + 90 dB = 100 dB
100 dB + 95 dB = 101 dB	

$$10\log\left(10^{\frac{100}{10}} + 10^{\frac{100}{10}}\right) = 103dB$$

Equal Loudness Contour – Human Perception

- Equal loudness contours have been developed which show the increase and decrease in sound level energy required at various frequencies for the average human to perceive sound in a particular frequency as sounding just as loud as that of a 20 dB sound pressure level at 1000 Hz.

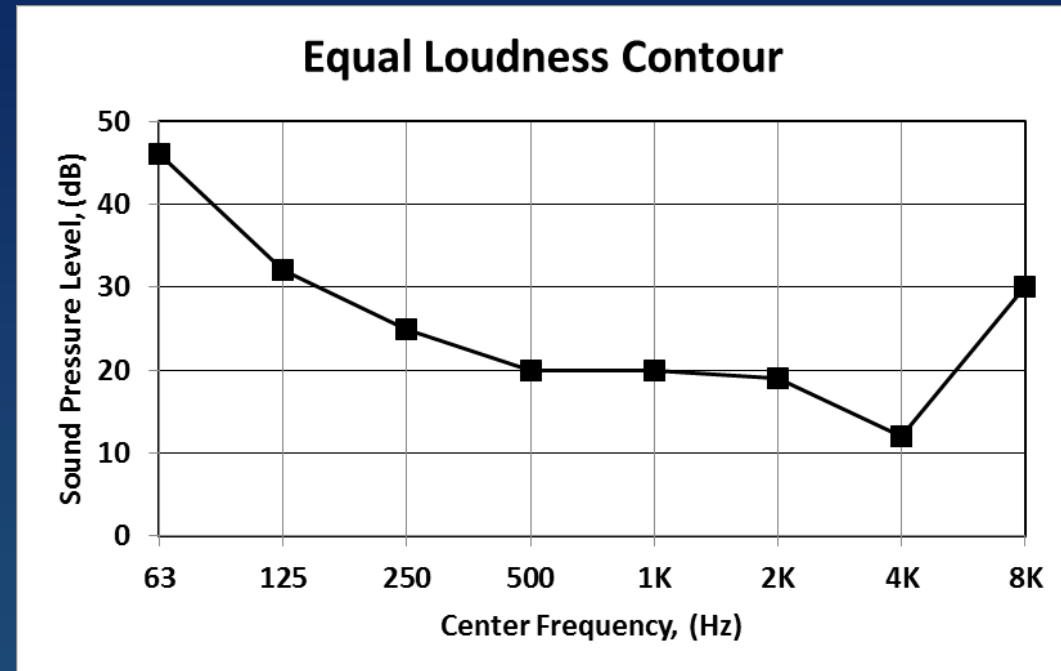

Noise Criteria (NC)

- A series of standardized curves that define a maximum allowable L_p for each frequency band.
- The appropriate NC curve is the highest curve defined by any of the frequency components.
- Predominant indoor design criterion for HVAC systems.

Allowable Sound Pressure Level (dB) per Frequency vs. NC Level

Freq. (Hz)	NC-Level										
	65	60	55	50	45	40	35	30	25	20	15
63	80	77	74	71	67	64	60	57	54	51	47
125	75	71	67	64	60	56	52	48	44	40	36
250	71	67	62	58	54	50	45	41	37	33	29
500	68	63	58	54	49	45	40	35	31	26	22
1K	66	61	56	51	46	41	36	31	27	22	17
2K	64	59	54	49	44	39	34	29	24	19	14
4K	63	58	53	48	43	38	33	28	22	17	12
8K	62	57	52	47	42	37	32	27	21	16	11

Noise Criteria (NC)

	NC Level
Churches, Mosques, Synagogues	25
Residences/Hotels – Living Areas/Suites	30
School Classroom	30
Commercial – Open Plan Office	40
Corridors & Lobbies	40

- Common accepted values.

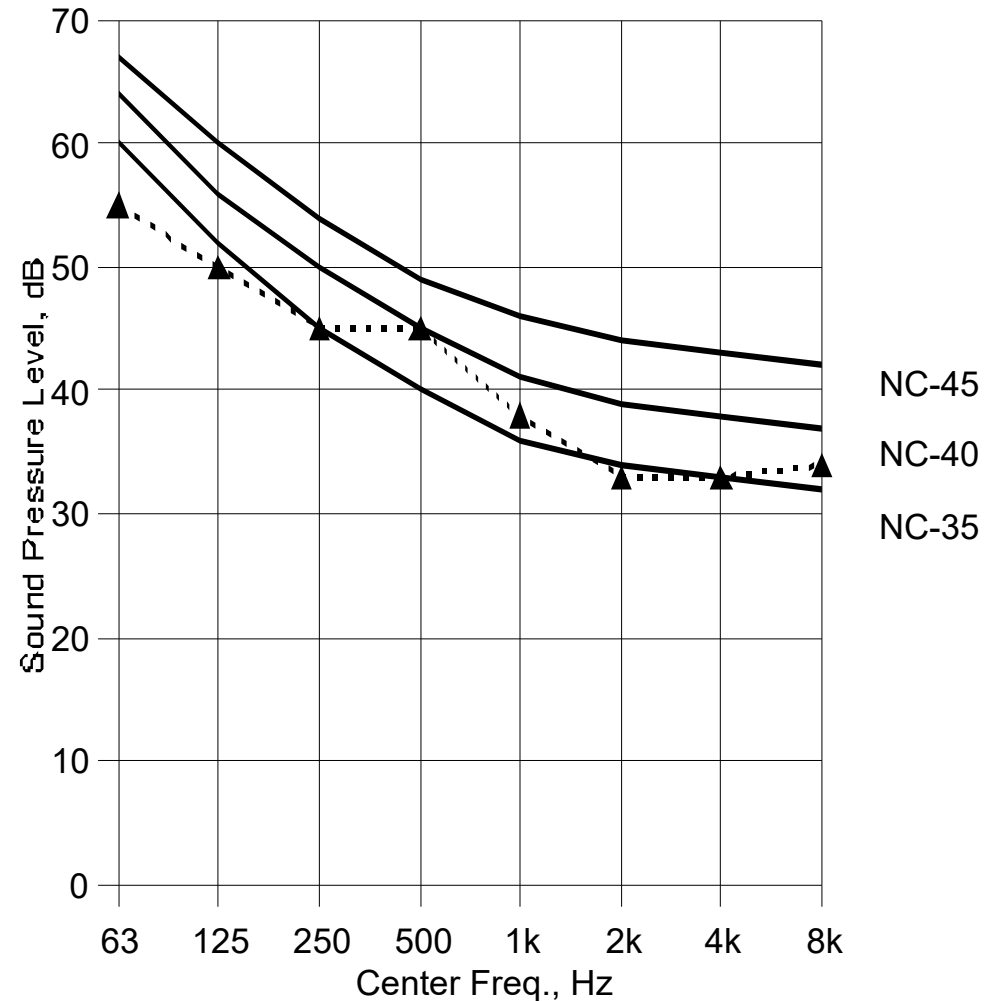

Noise Criteria (NC)

Rumble & Hiss

- Do not over-attenuate high frequencies
- A rumble noise problem will be created
- Do not over-attenuate low frequencies
- A hissing noise problem will be created

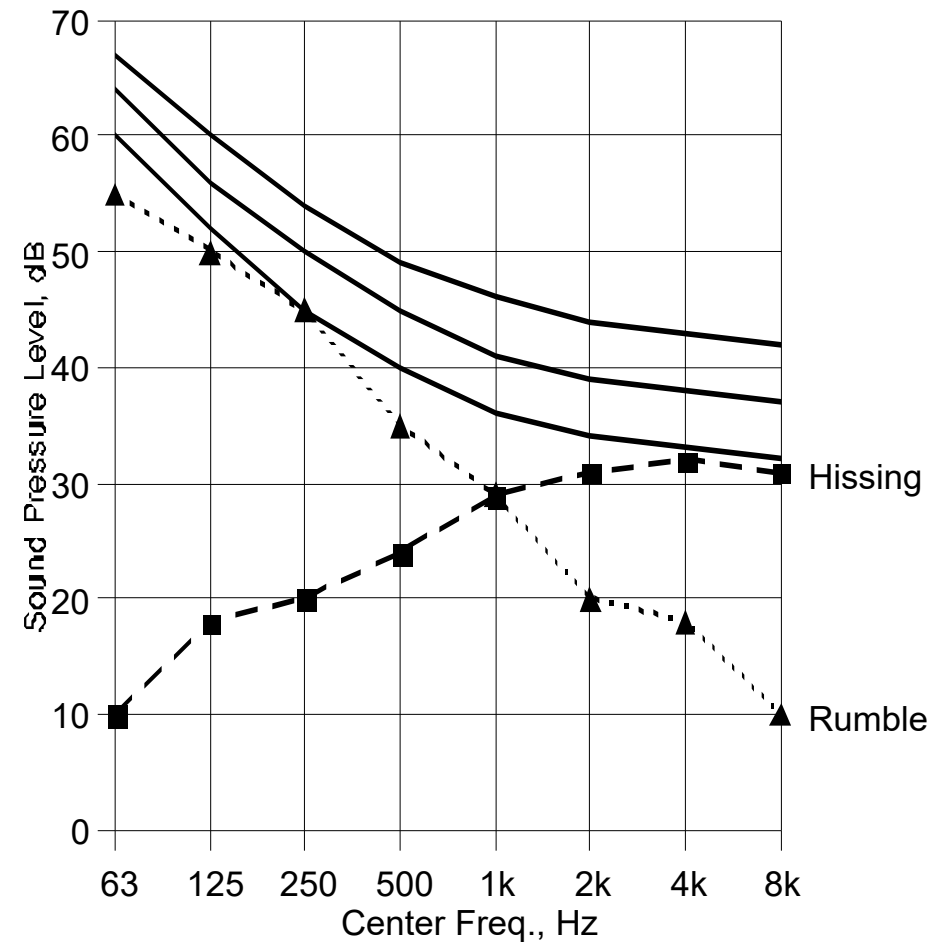

The HVAC System: Sound Paths

Sound Source Paths:

Path A – Structure-borne path through floor

Path B – Airborne path through supply system

Path C – Duct breakout from supply air duct

Path D – Airborne path through return system

Path E – Airborne path through mechanical equipment room

Paths B, C and D are within the scope of the HVAC designer.

Natural Attenuation

Duct elements in the HVAC System dissipate acoustic energy of the sound wave along the sound path.

This is caused by:

- Duct vibration
- Sound wave reflections
- Flow branching

Unlined Ductwork

- In-duct sound energy transmitted to duct surface.
- Function of duct shape and size.
- Can produce a significant amount of attenuation in long duct runs.

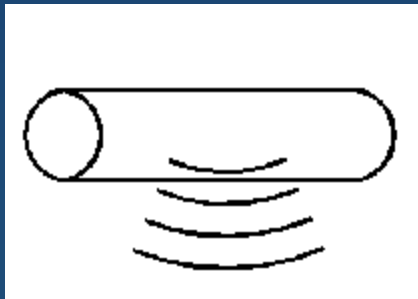

Duct Size (in x in)	Perimeter/ Area (1/ft.)	Attenuation in Unlined Rectangular Duct (dB/ft.)			
		Octave Band Center Frequency (Hz)			
		63	125	250	> 250
6 x 6	8.0	0.30	0.20	0.10	0.10
12 x 12	4.0	0.35	0.20	0.10	0.06
12 x 24	3.0	0.40	0.20	0.10	0.05
24 x 24	2.0	0.25	0.20	0.10	0.03
48 x 48	1.0	0.15	0.10	0.07	0.02

Diameter	Attenuation in Unlined Round Duct (dB/ft.)						
	Octave Band Center Frequency (Hz)						
	63	125	250	500	1K	2K	4K
$D \leq 7$	0.03	0.03	0.05	0.05	0.10	0.10	0.10
$7 < D \leq 15$	0.03	0.03	0.03	0.05	0.07	0.07	0.07
$15 < D \leq 30$	0.02	0.02	0.02	0.03	0.05	0.05	0.05
$30 < D \leq 60$	0.01	0.01	0.01	0.02	0.02	0.02	0.02

Lined Ductwork

- Increase in attenuation in mid and high bands over unlined.
- Typically not enough attenuation in the 63 Hz and 125 Hz bands for mechanical noise.
- Useful for eliminating generated noise, noise from a VAV box or in-branch duct element.
- 1" or 2" lining thickness. (common)

Diameter (in)	Attenuation in Lined Round Duct (dB/ft.)							
	Octave Band Center Frequency (Hz)							
	63	125	250	500	1K	2K	4K	8K
6	0.38	0.59	0.93	1.53	2.17	2.31	2.04	1.26
12	0.23	0.46	0.81	1.45	2.18	1.91	1.48	1.05
18	0.13	0.35	0.69	1.37	2.01	1.56	1.10	0.90
24	0.07	0.25	0.57	1.28	1.71	1.24	0.85	0.80

Duct Size (in x in)	Insertion Loss for Lined Rectangular Duct w/ 1-in. Fiberglass (dB/ft.)					
	Octave Band Center Frequency (Hz)					
	125	250	500	1K	2K	4K
6 x 6	0.6	1.5	2.7	5.8	7.4	4.3
6 x 18	0.5	1.0	2.2	4.7	5.2	3.3
8 x 8	0.5	1.2	2.3	5.0	5.8	3.6
8 x 24	0.4	0.8	1.9	4.0	4.1	2.8

Duct Breakout

- When acoustic sound energy radiates through the duct walls into the surrounding area.
- Increasing duct gauge and stiffness reduces breakout.
- Reduce sound power level in duct.

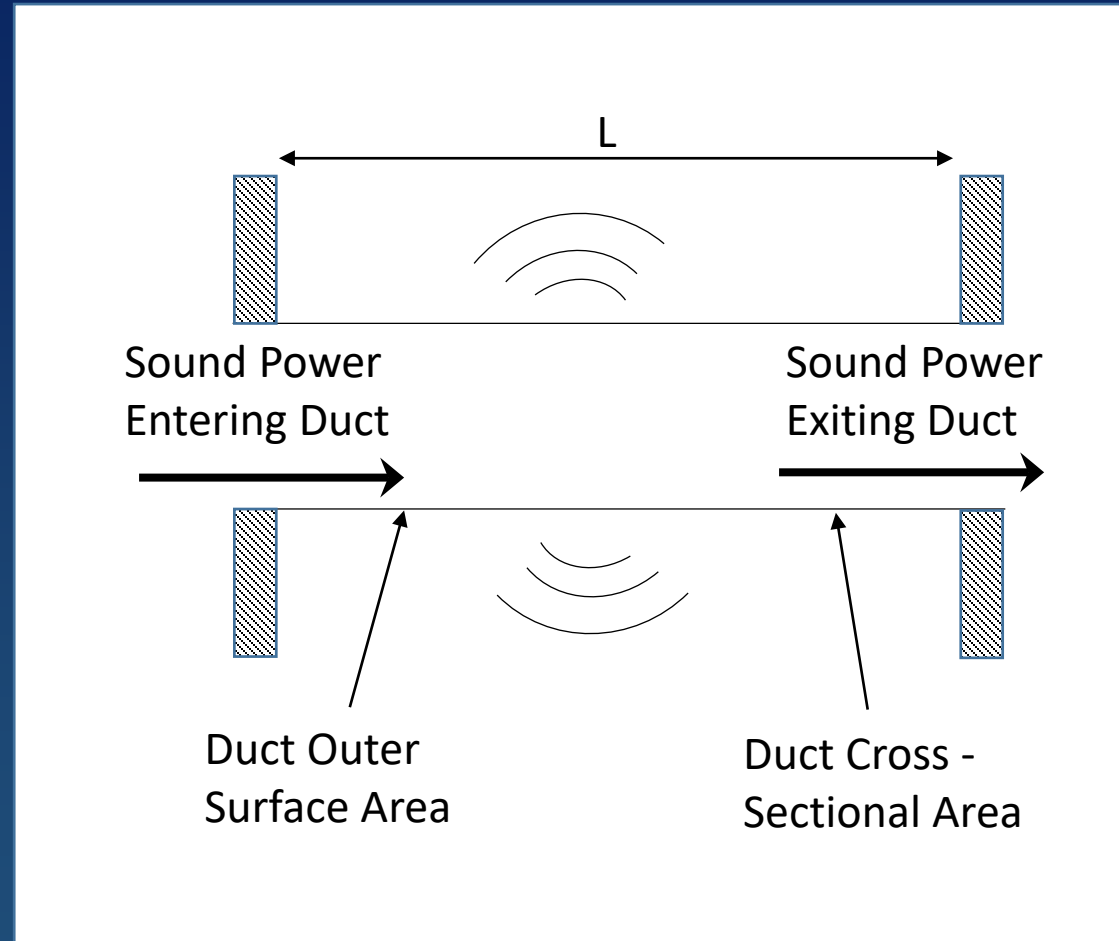

Duct Elbows

- Acoustic energy loss due to reflection of the sound wave.
- Can be a significant source of attenuation if multiple elbows are in the system.
- Unlined/lined, radius, mitered, with/without turning vanes, all have different attenuation levels.

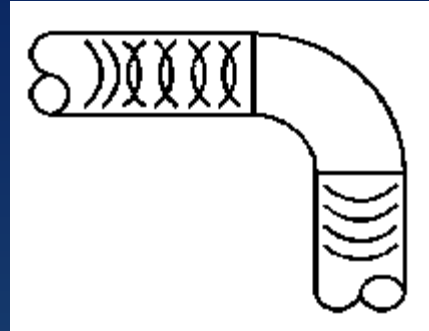

Insertion Loss of Radius Rectangular Elbows	
$fw = f \times w$ (f = center frequency, kHz and w = width, inches)	Insertion Loss (dB)
$fw < 1.9$	0
$1.9 \leq fw < 3.8$	1
$3.8 \leq fw < 7.5$	2
$fw > 7.5$	3

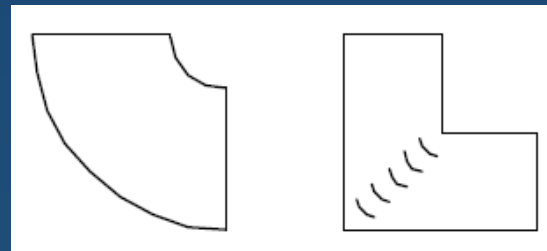

Insertion Loss of Unlined and Lined, Mitered Elbows with Turning Vanes		
$fw = f \times w$ (f = center frequency, kHz and w = width, inches)	Insertion Loss (dB)	
	unlined	lined
$fw < 1.9$	0	0
$1.9 \leq fw < 3.8$	1	1
$3.8 \leq fw < 7.5$	4	4
$7.5 \leq fw < 15$	6	7

Power Splits

- Most significant mechanism of natural attenuation.
- Energy In = Energy Out
- Energy division is according to the ratio areas.
- Typical HVAC design equates flow ratio and area ratio.
- Plenums can use the same logic in reducing noise with one supply and multiple discharges

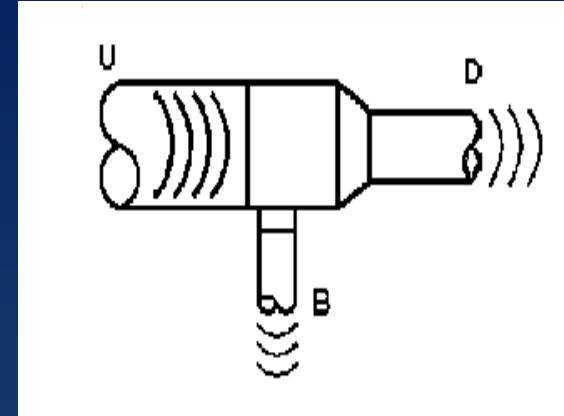

$$\Delta Lwu_{-b} = 10 \log [A_b / (A_u + A_b)]$$

$$\Delta Lwu_{-d} = 10 \log [A_d / (A_u + A_d)]$$

$$A = ft^2$$

$$\Delta Lw = dB$$

End Reflection

- Incident sound energy is reflected back when the sound wave expands into a large space.
- Good low frequency attenuation.
- Near zero attenuation above 63Hz when termination is connected to flexible duct or register or diffuser.
- If rectangular duct, use equivalent diameter

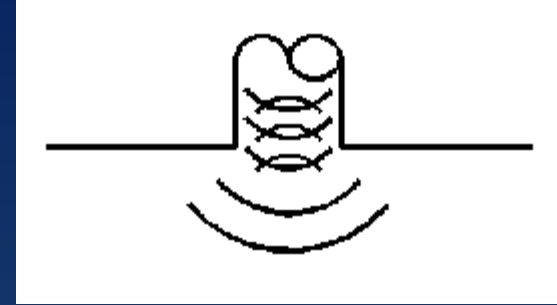

Diameter in)	Duct End Reflection Loss – Duct Terminated Flush with Wall (dB)				
	Octave Band Center Frequency (Hz)				
	63	125	250	500	1K
6	18	12	7	3	1
12	12	7	3	1	0
24	7	3	1	0	0
36	4	2	0	0	0
48	3	1	0	0	0

The Room Effect

- The room effect takes into account the environment that the sound power level (L_w) is in.
- This equation is for normal rooms with some level of sound absorption within the space including furnishings.
- The result is the sound pressure level in the space.
- The resultant sound pressure level (L_p) is compared against NC Curves to determine the required amount of attenuation.

$$L_p = L_w - 5 \text{ Log } (V) - 3 \text{ Log } (f) - 10 \text{ Log } (r) + 25 \text{ dB}$$

L_p = room sound pressure (dB re 20×10^{-5} Pa)

L_w = source sound power (dB re 1×10^{-12} watts)

V = room volume (ft.³)

f = octave band center frequency (Hz)

r = reference distance from diffuser (ft.)

Duct System Acoustic Analysis: An Example

- Determine the most sensitive space on the HVAC system.
- Start with the sound power level of the sound source.
- Deduct the natural attenuation of the HVAC system.
- Calculate the sound pressure spectrum and compare against NC Curves.





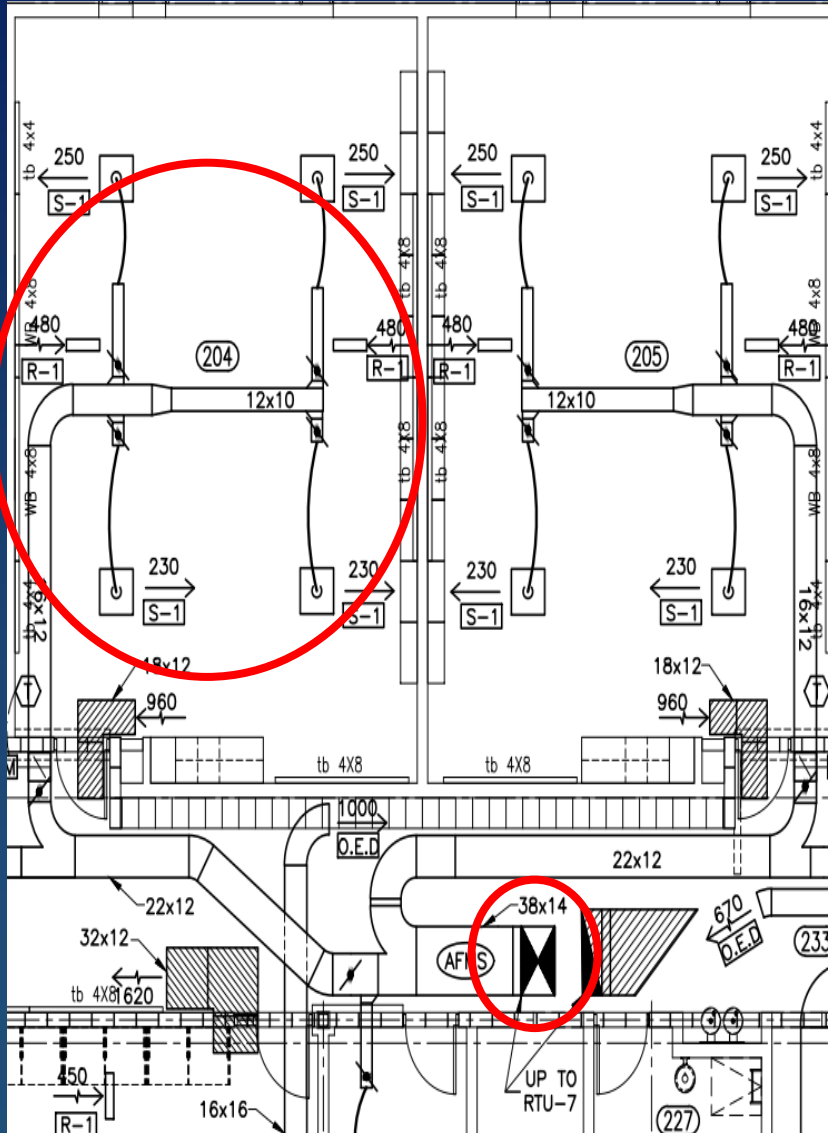





Job Information		Unit Information						
Job Name:	WXCDSB - New Catholic School	Approx. Op. Ship Weights:	1151 / 1151 lbs.					
Job Number:	2122222	Supply CFM/SP:	3500 / 0.75 in. wg.					
Site Altitude:	0 ft	Final Filter FV / Qty:	328.75 fpm / 4					
Refrigerant:	R-410A	Outside CFM:	525					
		Ambient Temperature:	50 °F DB / 55 °F WB					
		Return Temperature:	25 °F DB / 62.5 °F WB					
Static Pressure		Economizer:						
External:	0.75 in. wg.		0.05 in. wg.					
Evaporator:	0.82 in. wg.	Heating:	0.11 in. wg.					
Filters Clean:	0.17 in. wg.	Cabinet:	0.12 in. wg.					
Dirt Allowance:	0.85 in. wg.	Total:	1.90 in. wg.					
Cooling Section		Heating Section						
	Gross	Net	Std (No Preheat)					
Total Coils:	14.26	14.11	14.11					
Std								
Leak								
Min								
Est								
Leak								
Leak								
Dis								
Stat								
SA								
Est								
Est								
Ret								
Cool								
Cool								
Cool								
Rate								
App								
Electrical Data								
Rating:	575/3/60	Minimum Circuit Amp:	17					
Unit FLA:	15	Maximum Overcurrent:	25					
	Qty	HP	VAC	Phase	RPM	FLA	RLA	
Compressor 1:	1		575	3			9.9	
Condenser Fans:	1	0.75	460	1	1075	2.3		
Supply Fan:	1	2.00	575	3	1700	2.7		
Combustion:	1	0.09	460	1	3000	0.7		
Cabinet Sound Power Levels*								
Octave Bands:	63	125	250	500	1000	2000	4000	8000
Discharge LW(dB):	84	83	86	81	74	72	68	62
Return LW(dB):	79	78	76	68	65	62	56	47
*Sound power levels are given for informational purposes only. The sound levels are not guaranteed.								

The Acoustic Calculation: Supply System



- Lw for RTU-7 Discharge
- Duct:
 - 38x14", 5'
 - 22x12", 15'
 - 16x12", 15'
 - 8"Ø, 4'
- Elbows:
 - 14", 22", 16", 16"
- End Reflection:
 - 8"Ø
- Power Split:
 - $230/3350 \text{ CFM} = 7\%$
- Room Effect:
 - 20x30x9', 4-diffuser array, NC-35

The Acoustic Calculation: Supply System

HVAC ACOUSTIC ANALYSIS END NOISE									
Octave Band Center Frequency, Hz:	63	125	250	500	1 k	2 k	4 k	8 k	Description:
 Fan PWL:	82	83	84	79	72	70	66	60	No Prediction, Flow Volume (cfm) : 3350, Fan Operating Pressure (in. wg) : 0.75 Efficiency (%): 58.7
 Duct 38x14:	1	1	1	0	0	0	0	0	38 x 14 - (in) duct, 5 (ft) long, Unlined
 Duct 22x12:	6	3	2	1	1	1	1	1	22 x 12 - (in) duct, 15 (ft) long, Unlined
 Duct 16x12:	6	3	2	1	1	1	1	1	16 x 12 - (in) duct, 15 (ft) long, Unlined
 Duct 8dia:	0	0	0	0	0	0	0	0	8 - (in) dia duct, 4 (ft) long, Unlined
Total Duct Attenuation:	13	7	5	2	2	2	2	2	Total Duct Attenuation
 Elbow Duct 14:	0	0	1	5	8	4	3	3	Width (in) : 14, Qty : 1, Square Unlined
 Elbow Duct 22:	0	1	2	3	3	3	3	3	Width (in) : 22, Qty : 1, Radiused Unlined
 Elbow Duct 16:	0	2	4	6	6	6	6	6	Width (in) : 16, Qty : 2, Radiused Unlined
Total Elbow Duct Attenuation:	0	3	7	14	17	13	12	12	Total Elbow Duct Attenuation
 End Reflection:	16	10	6	2	1	0	0	0	Duct Terminated Flush with a Wall, 8 (in) Dia
 Branch SP division:	12	12	12	12	12	12	12	12	Branch Flow (cfm) : 230
PWL in Room:	41	51	54	49	40	43	40	34	PWL in Room
PWL to SPL:	5	6	7	8	9	10	11	12	Room Correction - Normal Office / Classroom, Width (ft) :
Multi-Terminal Correction:	6	6	6	6	6	6	6	6	30, Height (ft) : 9, Length (ft) : 20
Room SPL	42	51	53	47	37	39	35	28	Room SPL = 48 dBA
A-weighted values :	15	34	44	43	37	40	36	26	A-weighted values
Design Level:	60	52	45	40	36	34	33	32	NC - 35
Required Attenuation:	0	0	8	7	1	5	2	0	Required Attenuation

Notes: In general, Predictions are based on ASHRAE HVAC APPLICATIONS, 2007.



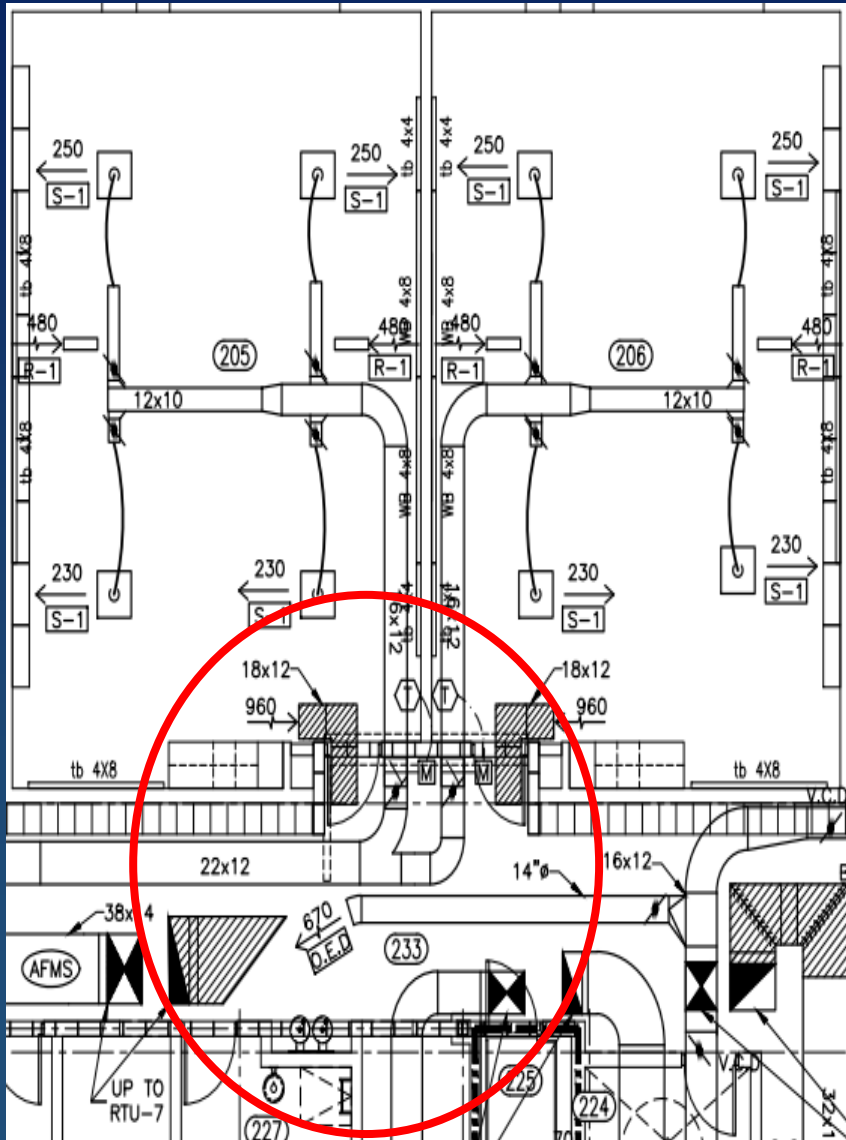

The accuracy of this evaluation is dependent upon the accuracy of the Fan Sound Power Levels, and ASHRAE Data and Calculations Methods.

The Acoustic Calculation: Return System



- Lw for RTU-7 Return
- Duct:
 - 44.5x13.5", 1'
- Elbow:
 - 13.5"
- Ceiling Tile IL:
 - Glass Fiber Tile: 3/6/5/7/7/8/9/9
 - Gypsum: 8/11/15/15/17/17/18/18
- End Reflection:
 - 44.5x13.5"
- Room Effect:
 - 8x30x12', single source, NC-40

The Acoustic Calculation: Return System

HVAC ACOUSTIC ANALYSIS END NOISE									
Octave Band Center Frequency, Hz:	63	125	250	500	1 k	2 k	4 k	8 k	Description:
 Fan PWL:	74	71	72	63	60	56	50	39	No Prediction, Flow Volume (cfm) : 3350, Fan Operating Pressure (in. wg) : 0.75 Efficiency (%): 58.7
 Duct 44.5x13.5:	0	0	0	0	0	0	0	0	44.5 x 13.5 - (in) duct, 1 (ft) long, Unlined
Total Duct Attenuation:	0	0	0	0	0	0	0	0	Total Duct Attenuation
 Elbow Duct 13.5:	0	0	1	5	8	4	3	3	Width (in) : 13.5, Qty : 1, Square Unlined
Total Elbow Duct Attenuation:	0	0	1	5	8	4	3	3	Total Elbow Duct Attenuation
 End Reflection:	4	2	1	0	0	0	0	0	Duct Terminated in Free Space, 44.5 (in) Maximum Duct Dimension
 Other attenuation:	3	6	5	7	7	8	9	9	Glass Fiber Tile IL
PWL in Room:	67	63	65	51	45	44	38	27	PWL in Room
PWL to SPL:	6	7	8	9	10	11	12	13	Room Correction - Normal Office / Classroom, Width (ft) : 30, Height (ft) : 12, Length (ft) : 8
Room SPL	61	56	57	42	35	33	26	14	Room SPL = 49 dBA
A-weighted values :	34	39	48	38	35	34	27	12	A-weighted values
Design Level:	64	56	50	45	41	39	38	37	NC - 40
Required Attenuation:	0	0	7	0	0	0	0	0	Required Attenuation

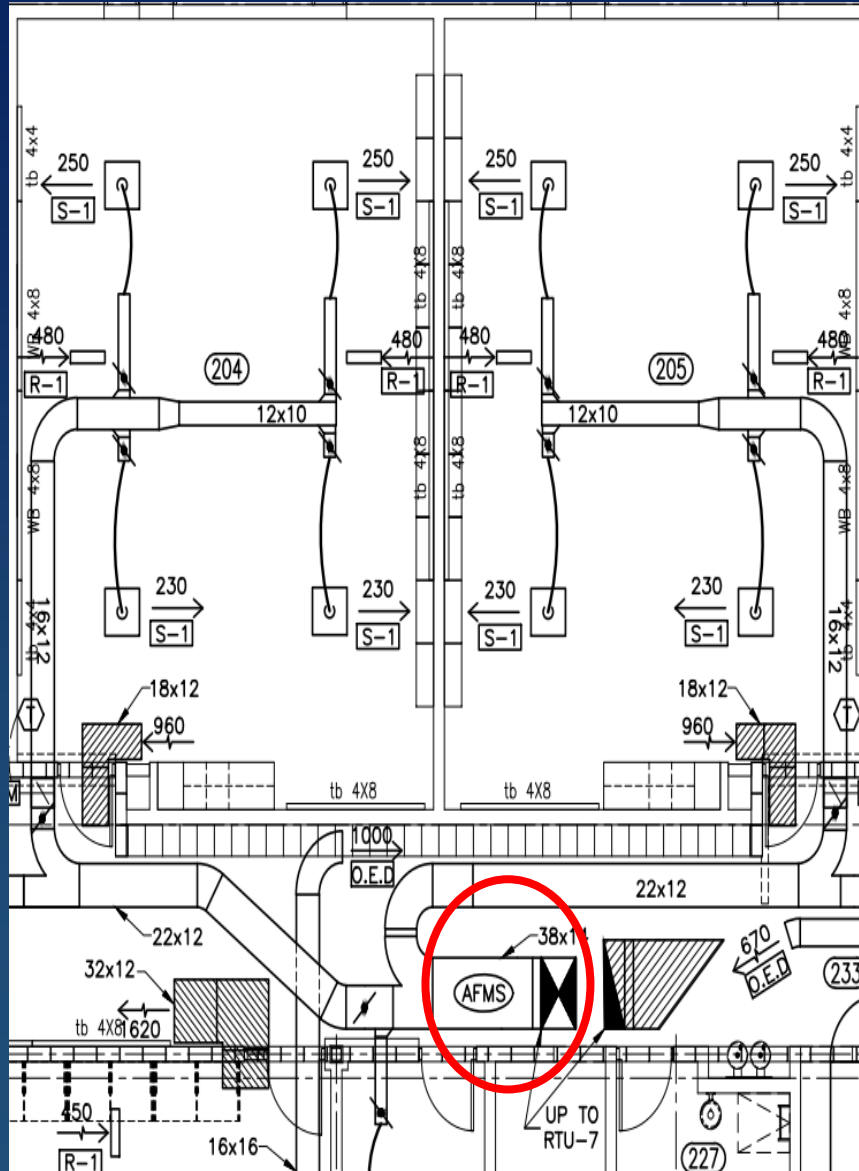

Notes: In general, Predictions are based on ASHRAE HVAC APPLICATIONS, 2007.
The accuracy of this evaluation is dependent upon the accuracy of the Fan Sound Power Levels, and ASHRAE Data and Calculations Methods.

The Acoustic Calculation: Break-Out



- L_w for RTU-7 Discharge
- Duct:
 - 38x14"
- Ceiling:
 - FG Ceiling Tile
- Room Criteria:
 - NC-40

The Acoustic Calculation: Break-Out

HVAC ACOUSTIC ANALYSIS BREAKOUT NOISE									
Octave Band Center Frequency, Hz:	63	125	250	500	1 k	2 k	4 k	8 k	Description:
 Fan PWL:	82	83	84	79	72	70	66	60	No Prediction, Flow Volume (cfm) : 3350, Fan Operating Pressure (in. wg) : 0.75, Efficiency (%): 58.7
 Breakout TLout:	23	26	29	32	32	38	44	45	44.5 x 13.5 (in) : 18 ga - Rectangular Duct
10 Log(S/A):	14	14	14	14	14	14	14	14	10 Log(S/A)
Breakout PWL:	73	71	69	61	54	46	36	29	Breakout PWL
Ceiling / Plenum / Room Effect :	3	6	5	7	7	8	9	9	Glass Fiber, 1.0 lb/ft2,
Duct Breakout Room Effect:	12	12	12	12	12	12	12	12	
Room SPL	58	53	52	42	35	26	15	8	Room SPL = 45 dBA
A-weighted values :	31	36	43	38	35	27	16	6	A-weighted values
Design Level:	64	56	50	45	41	39	38	37	NC - 40
Required Attenuation:	0	0	2	0	0	0	0	0	Required Attenuation
<p>Notes: In general, Predictions are based on ASHRAE HVAC APPLICATIONS, 2007. The accuracy of this evaluation is dependent upon the accuracy of the Fan Sound Power Levels, and ASHRAE Data and Calculations Methods.</p>									

- 2 dB is not significant and can be overlooked.

The Acoustic Calculation:

The Requirements

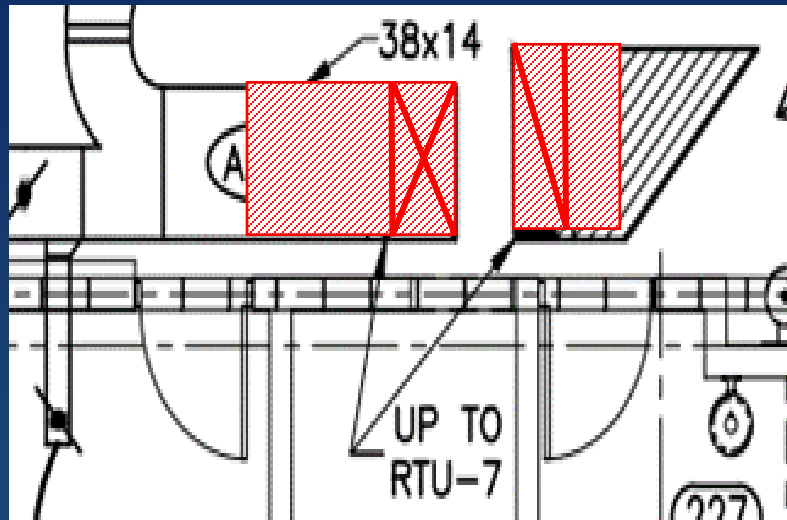

- **Supply System:**
 - Required Attenuation:
 - 0/0/8/7/1/5/2/0
 - Required Casing Gauge:
 - 18 Ga.
- **Return System:**
 - Required Attenuation:
 - 0/0/7/0/0/0/0/0
- **Select silencer:**
 - Equal to, or greater than, required attenuation
 - Note the pressure drop of the silencer

The Acoustic Calculation: The Selection

- Manufacturer software to select silencer model.
- Cross-section to match ductwork; length as needed.
- Pressure drop vs. length.
- Match silencer casing material to ductwork.
- Include Tedlar/FG, if required.
- Some Manufacturers offer services to perform acoustic calculations and produce product schedule.

Silencer Information

Pick Silencer Tag: Add Silencer

Model: 24VRS-F/3 - 120 x 24 x 24 **Price:** \$ 714.71

Silencer Configuration	Straight <input type="text"/>	
Quantity (r)	<input type="text" value="1"/>	
Number of Pieces	<input type="text" value="1"/>	
Width (in) (r)	<input type="text" value="24"/>	Restriction <input type="text" value="57.5"/>
Height (in) (r)	<input type="text" value="24"/>	Restriction <input type="text" value="57.5"/>
Length (in) (r)	<input type="text" value="120"/>	
RS Type	3 <input type="text"/>	
Flow Direction	Forward <input type="text"/>	
Fan System (r)	f <input type="text"/>	
Flow Volume (cfm) (r)	<input type="text" value="4,000"/>	

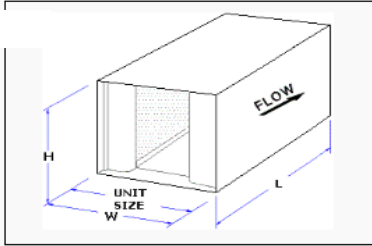

Face Velocity (fpm)(r) +

Pressure Drop (in wg)

Unit Size

Weight/Piece (lbs)

System Effect Factors (r)

63	125	250	500	1K	2K	4K	8K	PD
0	0	0	0	0	0	0	0	1

Dynamic Insertion Loss

63	125	250	500	1K	2K	4K	8K
11	21	32	49	50	32	20	17

Airflow Generated Noise

63	125	250	500	1K	2K	4K	8K
55	50	43	41	42	43	41	39

Silencer Options Selection

Casing Thickness	<input type="text" value="22 ga"/>	Acoustic Media	<input type="text" value="Fiberglass (standard)"/>
Perforated Liner Thickness	<input type="text" value="22 ga"/>	Covering	<input type="text" value="None"/>
Silencer Material	<input type="text" value="Galvanized Steel"/>	Application Method	<input type="text" value="None"/>

Miscellaneous Silencer Options

Solvent Cleaning
 Continuous Welded Joints
 Seams Locked and Caulked
 Individual Wrapping

The Silencer/Attenuator/Sound Trap

- Ducted, replaces section of ductwork.
- Can be fabricated to match any sheet metal shape and size.
- Straight rectangular, circular, elbow, transitional, “T” shapes.
- Three performance characteristics:
 - *Insertion Loss*
 - *Pressure Drop*
 - *Generated Noise*

The Silencer: Rectangular - Straight

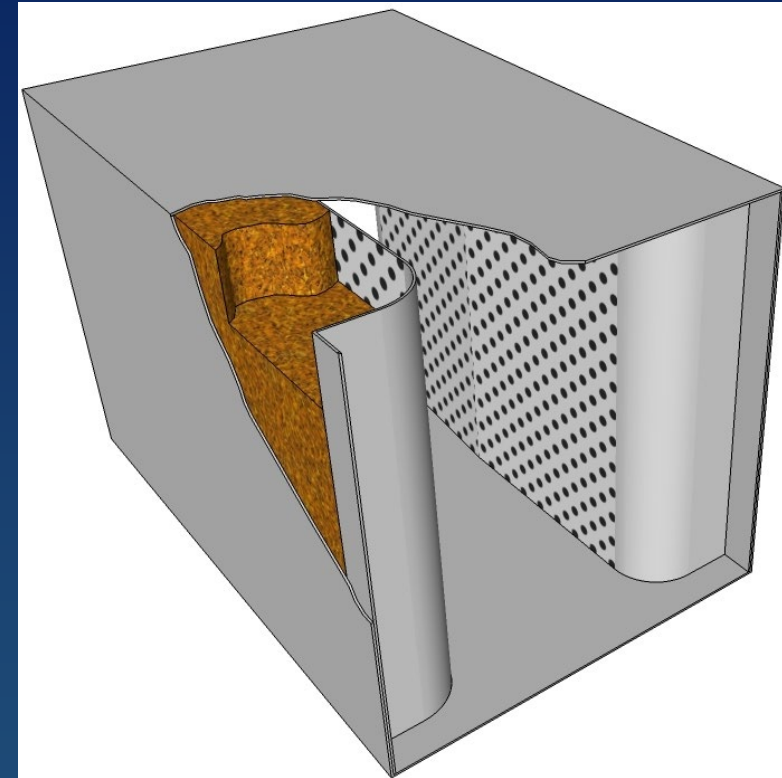
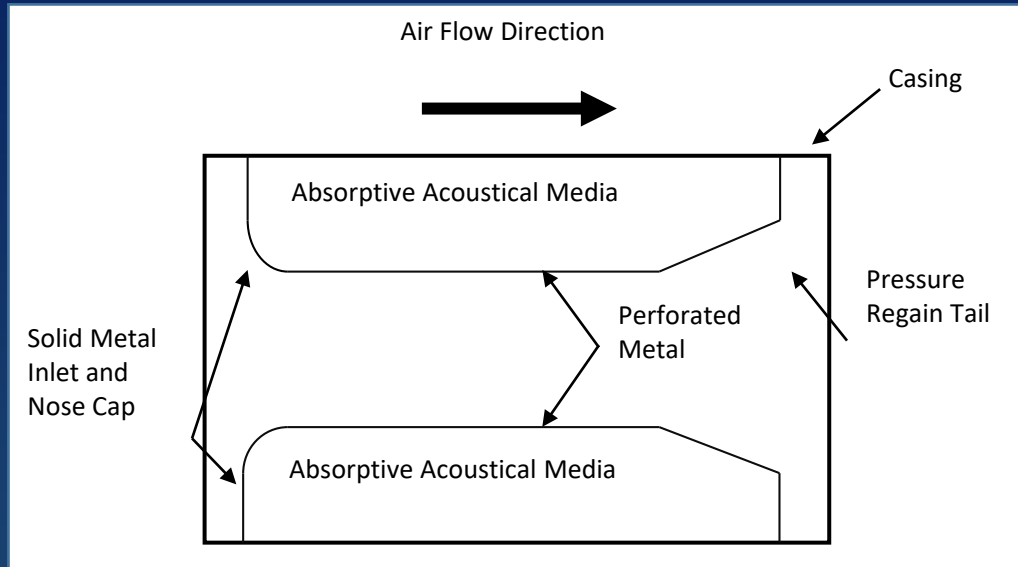

- **Std. Casing:** 22 Ga. – 16 ga. Galvanized sheet metal
- **Inlet & Nose Cap:** 22 Ga. Galvanized solid sheet metal
- **Perforated Baffle Face:** 22 Ga. Galvanized perforated sheet metal
- **Media:** Fiberglass or cotton fiber material

- Length, Width, Height, Passage Width, Baffle Width

The Silencer: Rectangular Elbow

- When to use:
 - If silencing cannot fit into the system in any other way, only then is it practical to use an elbow silencer.
- When not to use:
 - When lower cost, straight rectangular silencers will suffice.
- Space saving applications:
 - Congested fan rooms, AHU's, Industrial applications.
- Advantages:
 - Same or better insertion loss than straight silencers, low pressure drops if properly selected.

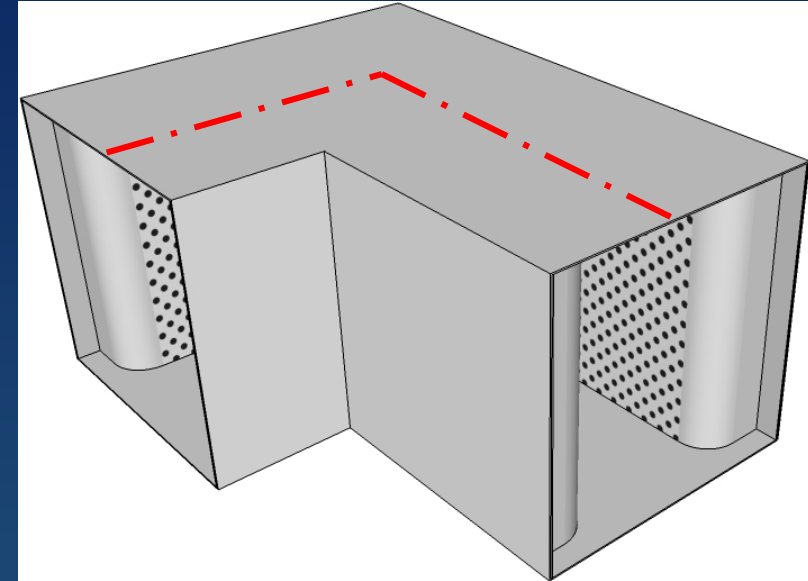

- Center Line Length, Width, Height, Passage Width, Baffle Width
- Curved air passage (not shown).

The Silencer: Round

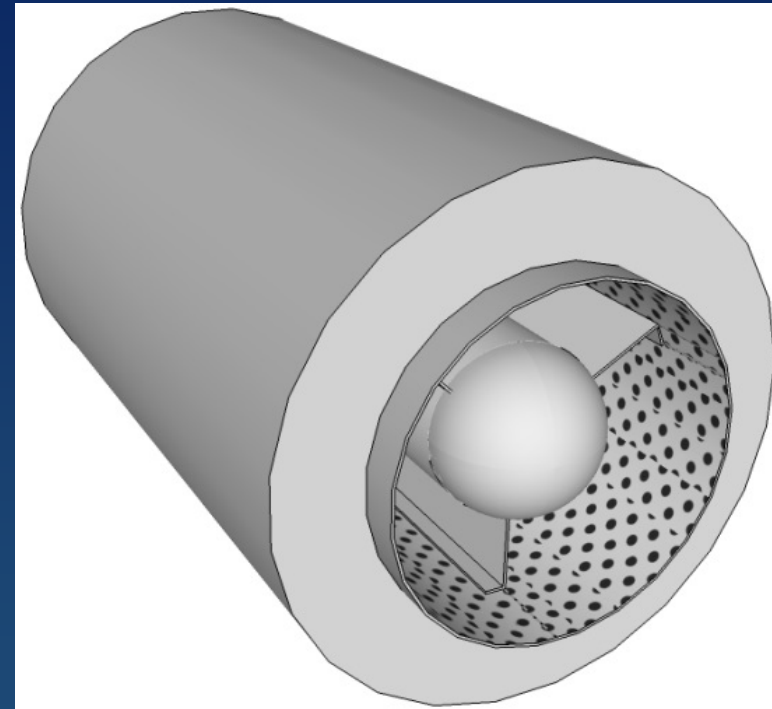
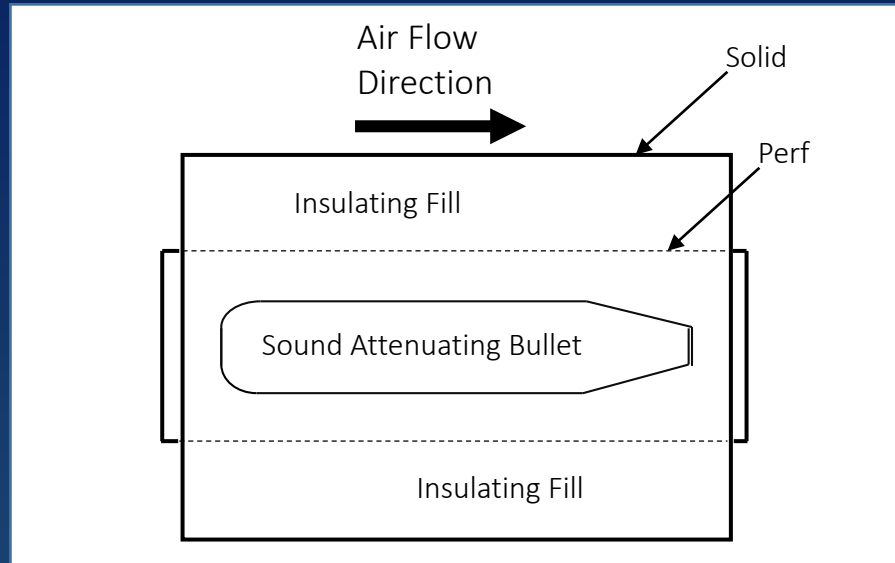

- **Std. Casing:** 22 Ga – 16 ga. Galvanized sheet metal
- **Inlet & Nose Cap:** 22 Ga. Galvanized solid sheet metal
- **Perforated Bullet Face:** 22 Ga. Galvanized perforated sheet metal
- **Media:** Fiberglass

- Length, ID, OD, Bullet Diameter

The Silencer: *Various Types*

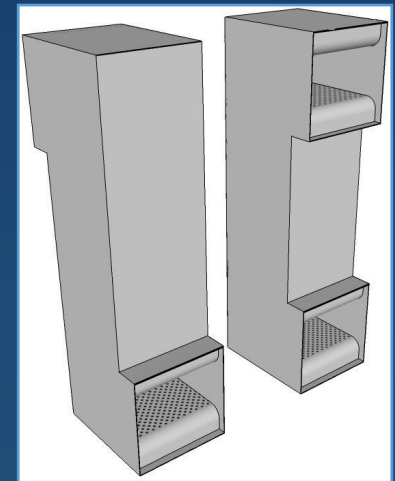
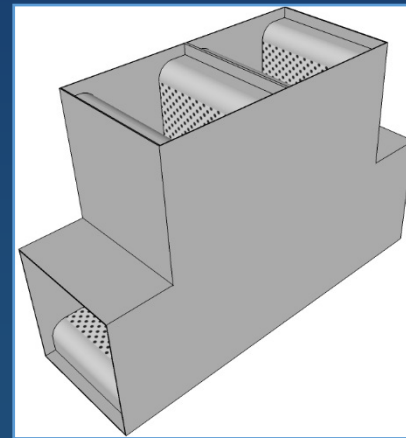
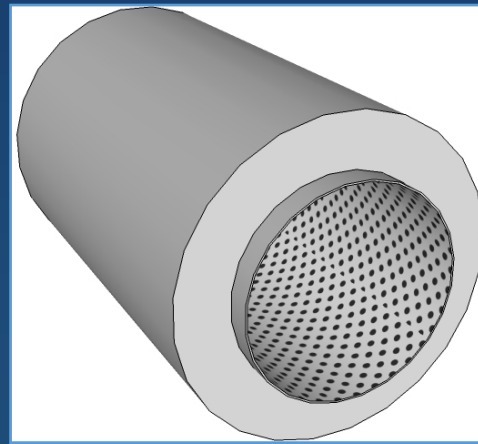
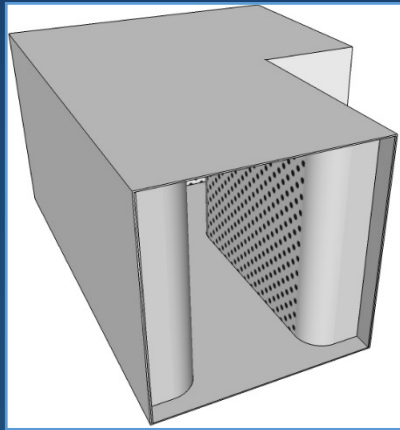
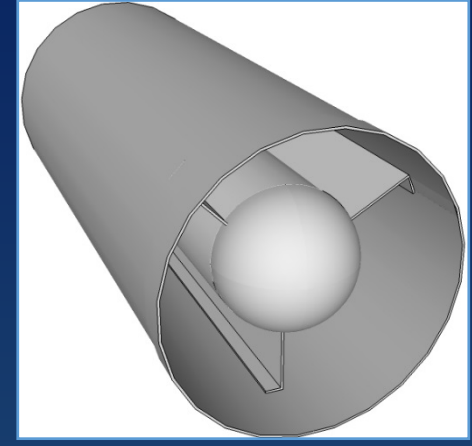
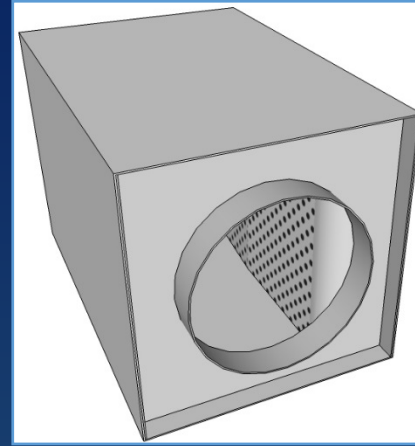
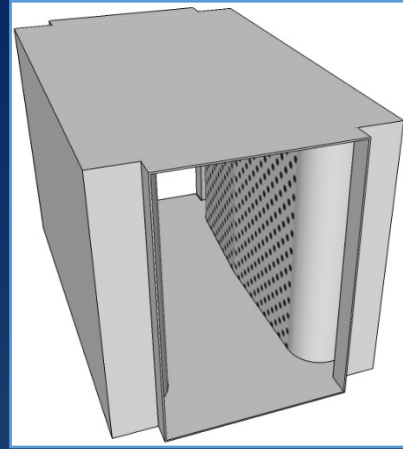
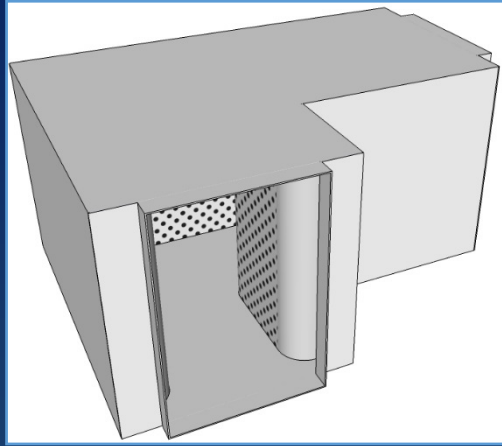

The Silencer: Insertion Loss

- Insertion loss is the difference in sound power level of a system with and without a silencer.
- Measured physically by measuring sound pressure levels.
- Insertion loss varies with sound frequency, airflow velocity airflow and direction.

The Silencer: Insertion Loss

Insertion Loss...A function of:

- **Entrance Loss (ΔL_{ENT})**
 - Small loss, contributes to high frequency attenuation
- **Passage Loss (ΔL_L)**
 - Major component of IL
 - \propto passage length, perimeter/area ratio
 - Wider baffle spacing for low frequency attenuation; narrow spacing for high frequency attenuation
 - % Open Area a key design parameter
- **Exit Loss (ΔL_{EX})**
 - Small loss, contributes to low frequency attenuation

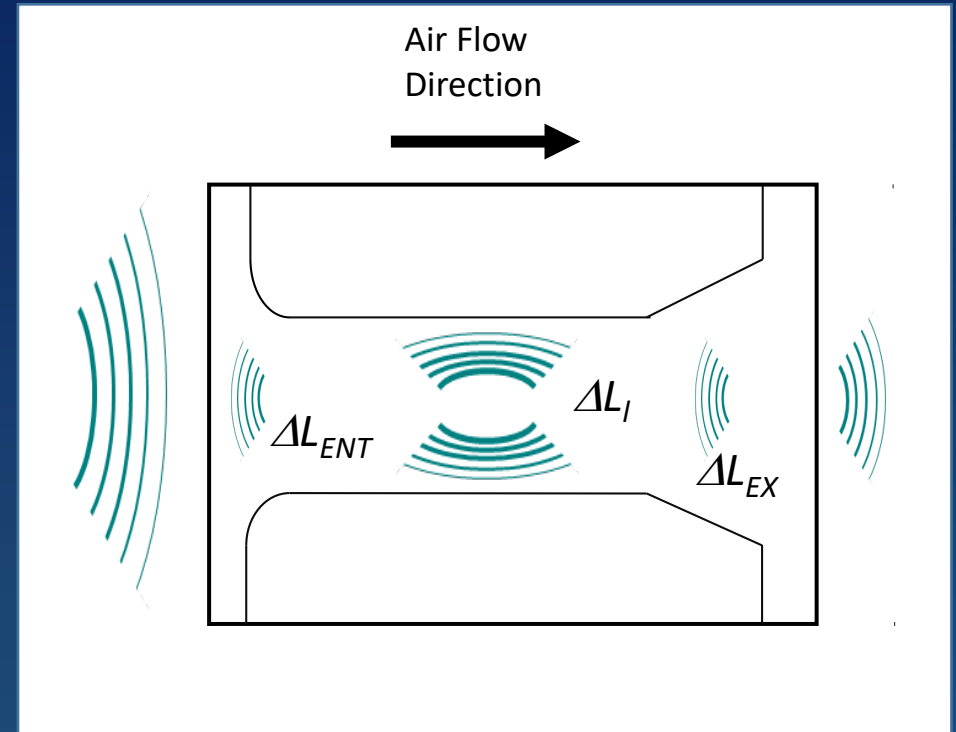

$$IL \approx \Delta L_{ENT} + \Delta L_L + \Delta L_{EX}$$

The Silencer: Pressure Drop

- Components to Pressure Drop
 - Entrance Loss (K_{ENT})
 - Loss due to compressing flow into air passages
 - Can be smaller loss if the baffles are rounded
 - Passage Loss (K_f)
 - Loss due to friction along the passage
 - Small loss
 - Exit Loss (K_{EX})
 - Loss due to sudden expansion into duct.
 - Largest contributor
 - Expansion tail reduces component by 15%

The Silencer: *System Effect Pressure Loss*

- System Effect:
 - Poor flow conditions can multiply the test reported pressure drop
 - Silencer placement is critical to determine actual pressure drop under system conditions
 - 3 duct diameter spacing
- Commercial duct silencers are typically selected for a pressure drop ≤ 0.35 " WG, including System Effects.
- 0.2"wg if System Effects are unknown.

The Silencer: **Generated Noise**

- Noise generated when air flows through a silencer air passage.
- GN is an absolute sound power level added to the system (logarithmic addition).
- GN is typically of concern for quiet HVAC systems (< NC 25).
- GN is not important when flow velocity is properly selected.

Noise Criteria	Max. Duct Velocity (fpm)
NC-40	1300
NC-35	1000
NC-30	800
NC-25	700

- Less of a concern for return systems

The Silencer: Media Lined / Unlined, No Media “Packless”

- Tedlar® Film + Acoustic Spacer
 - For healthcare or sensitive applications which cannot allow fiber shedding into the airstream
 - Greatly affects IL performance in mid bands. This must be reflected on the silencer schedule
- No Media
 - Metal chambers/resonators reduce sound power at a narrow band of frequencies.

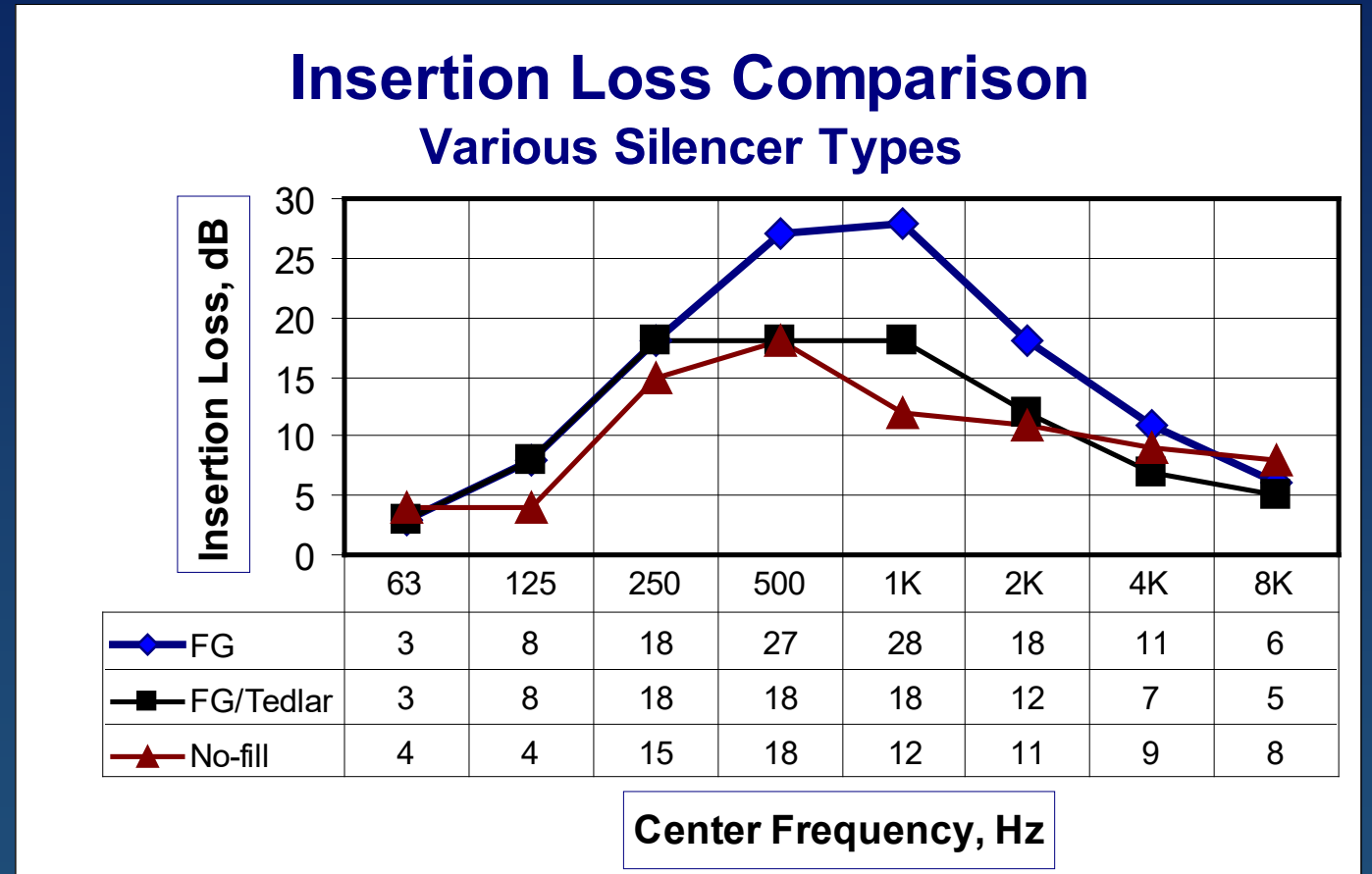

W=48”, H=36”, L = 60”, TPD = 0.21” WG, CFM = 15,000, FPM = 1250

The Silencer: Selection & Performance

- $\downarrow\%$ Open Area $\propto \uparrow$ PD $\propto \uparrow$ IL $\propto \uparrow$ GN
- \uparrow Length $\propto \uparrow$ IL $\propto \uparrow$ PD
- PD \propto Velocity²
- Trade off between PD, Length and IL.
- IL tuned by baffles:
 - More, thinner baffles = high frequency IL
 - Fewer, thicker baffles = low frequency IL

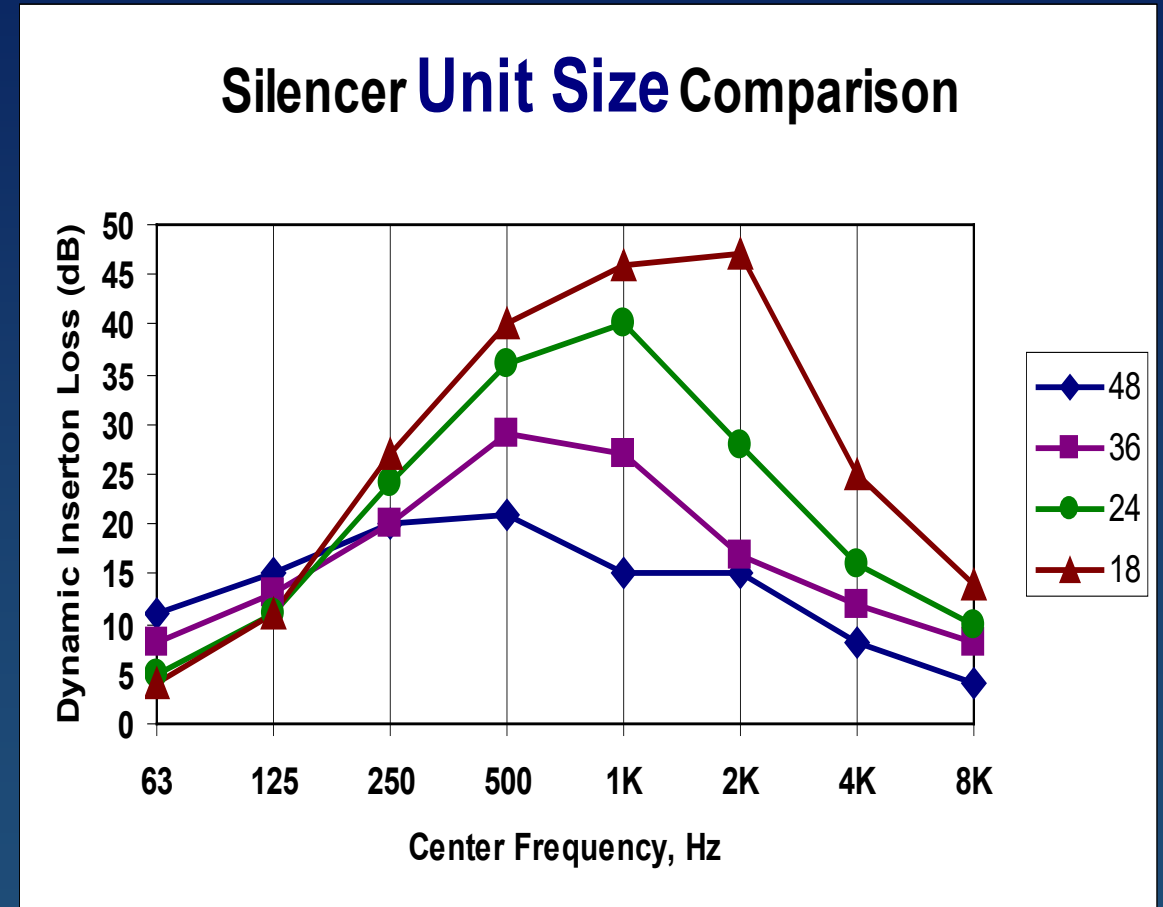

The Silencer: Location

- Locate silencer at mechanical room wall:
 - Usually better System Effects
 - Guards against break-in noise
 - Can use simple rectangular silencers; can avoid costly transitional elbow silencer
- Locate silencer at penetration into space:
 - High Transmission Loss silencer will guard against break-out noise

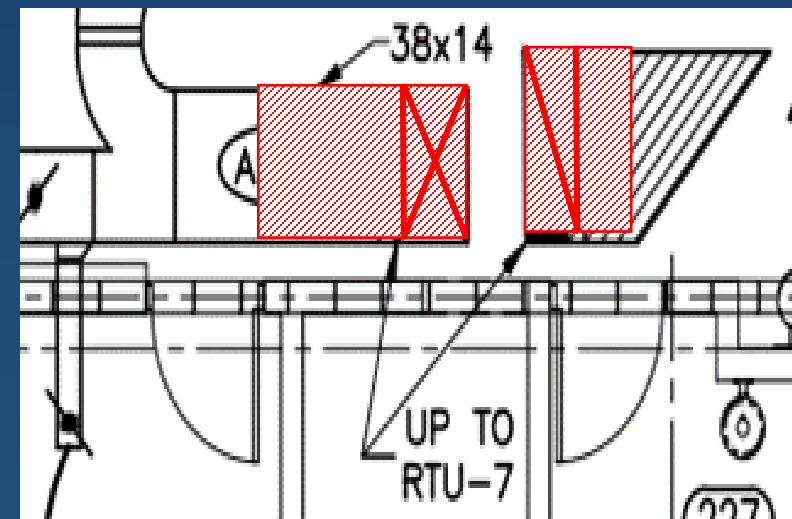
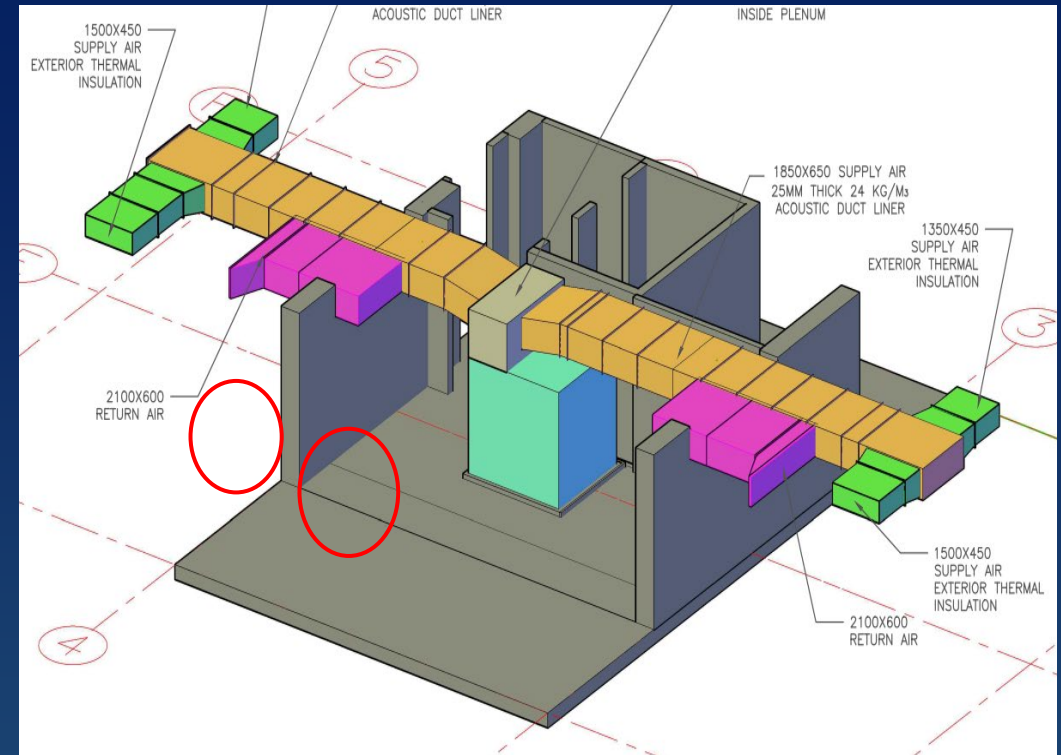

The Silencer: Location

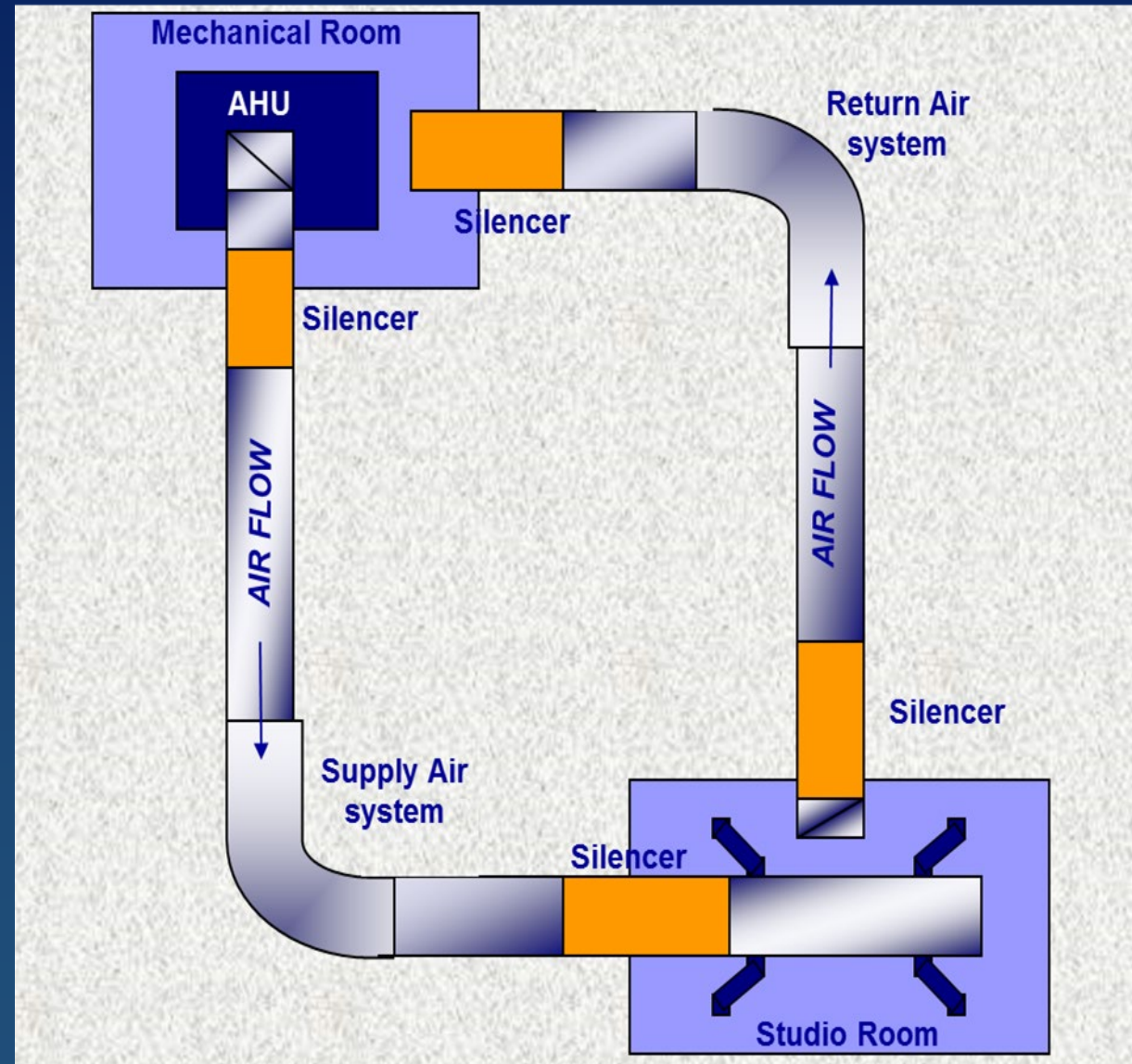
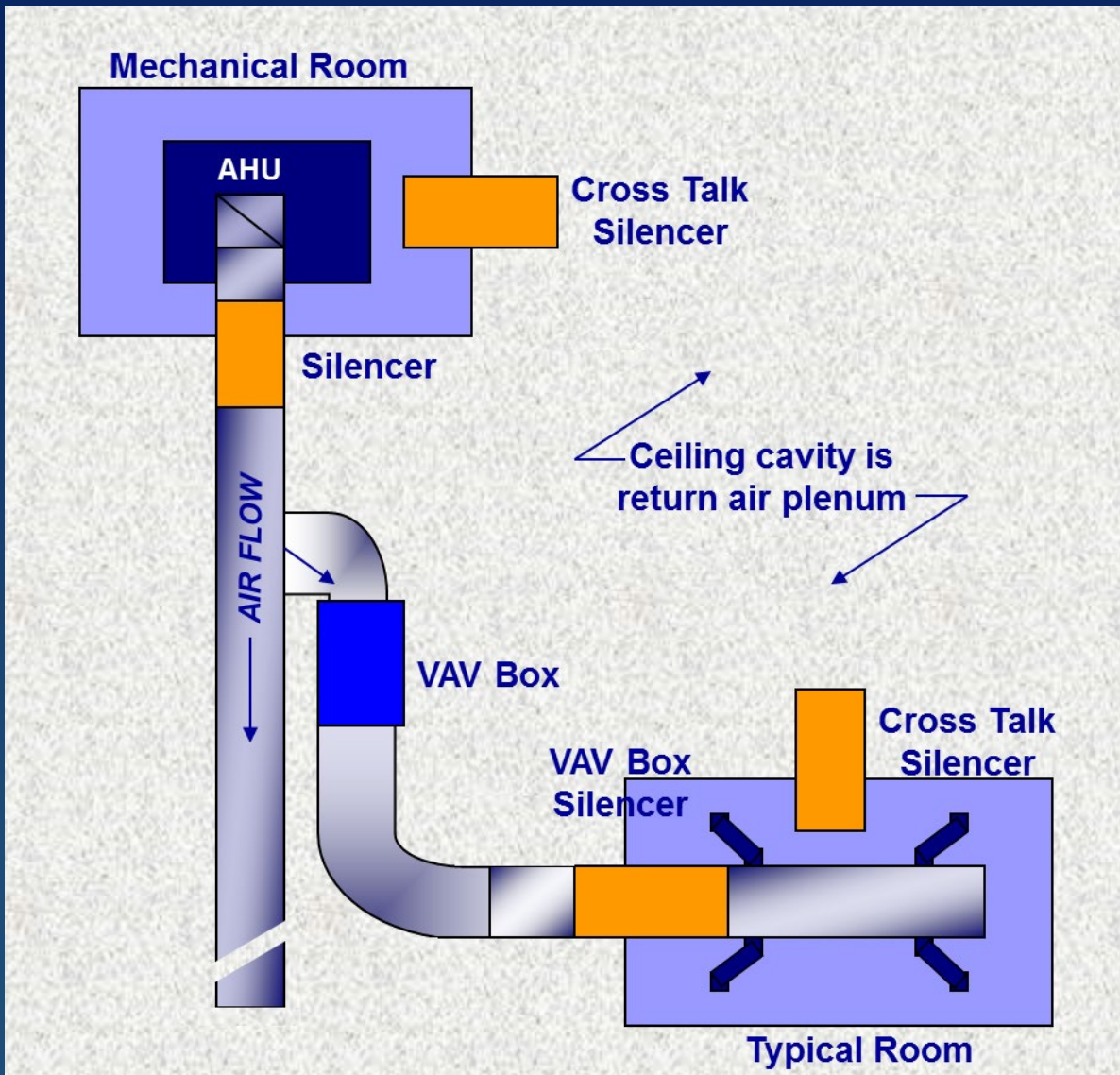

Acoustic Testing Standards

- **ASTM E477**, Standard test method for measuring **acoustical and airflow performance** of duct liner materials and prefabricated silencers
- **ASTM 423**, Standard test method for sound absorption and sound **absorption coefficients** by the reverberation room method
- **ASTM E90**, Standard test method for laboratory measurement of airborne sound **transmission loss** of building partitions and elements

Performance Testing: AMCA Certified Ratings

- Air Movement and Control Association International, Inc.
- Certified Ratings Assures:
 - reliable and accurate performance ratings;
 - published ratings are based on standard testing methods;
 - subject to review by AMCA International as an impartial authority;
 - AMCA online Directory of Certified Products: www.amca.org

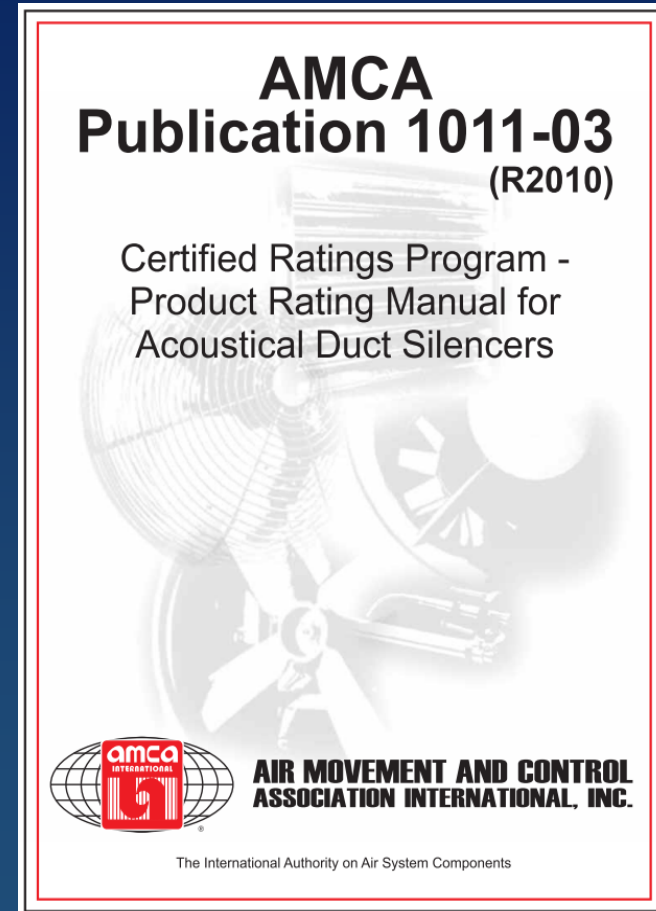

Questions?

John D. Sofra

**Market Manager - *Airflow Attenuation, Industrial,
Environmental Markets***

Kinetics Noise Control, Inc., Dublin, Ohio

jsofra@kineticsnoise.com

